

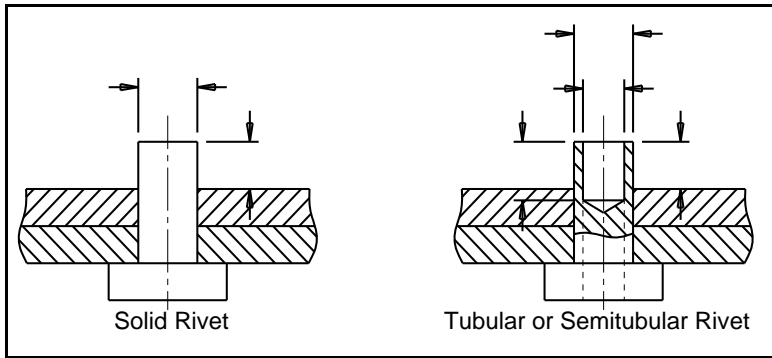

FINAL SHAPE (mark with an X)

							Other
Flat	Conical	Flat flanged	Crown	Flanged	Drawn	Pan Head	

DIMENSIONS OF THE RIVET (attach the drawing or mark here)



DIMENSIONS AFTER RIVETING (attach the drawing or mark here)

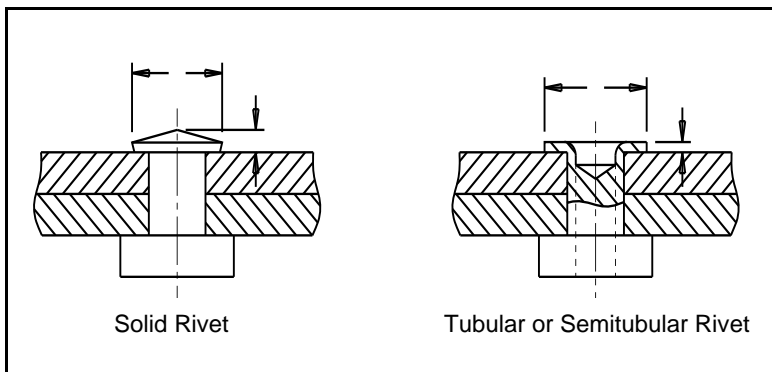

Important Notes:

- Although the riveting tools are tools with high resistance and durability, their life can be **reduced** if the riveting machine is **incorrectly set**. In these circumstances the warranty of the tools will not be covered.
- The manufacturing of a riveting tool **does not include** carrying out riveting trials. There are other reasons such as riveting pressure, stroke speed, length of the material to be riveted, hardness of the rivet, the rivet fixture, etc that have an influence on the final result. This is the reason why AGME declines all responsibility on the obtained final result.
- Industrias AGME can **guaranty** the final results of the riveting process only when the riveting tools are delivered in **a turnkey solution** or when the **tests** with the riveting tools have been previously included in the quotation and order.

